

CONCRETE CRUSHER BC 250 MK2 SMART-FORCE



Part no.
1107019



- 18V BATTERY
- POW3R PUMP
- CONNECT
- FORGED
- 360° HANDLE
- LED LIGHTS
- UNDERWATER

Technical data:

Opening width	250 mm
Weight (ready for use)	22,4 kg
Dimensions (LxWxH)	908 x 380 x 318 mm

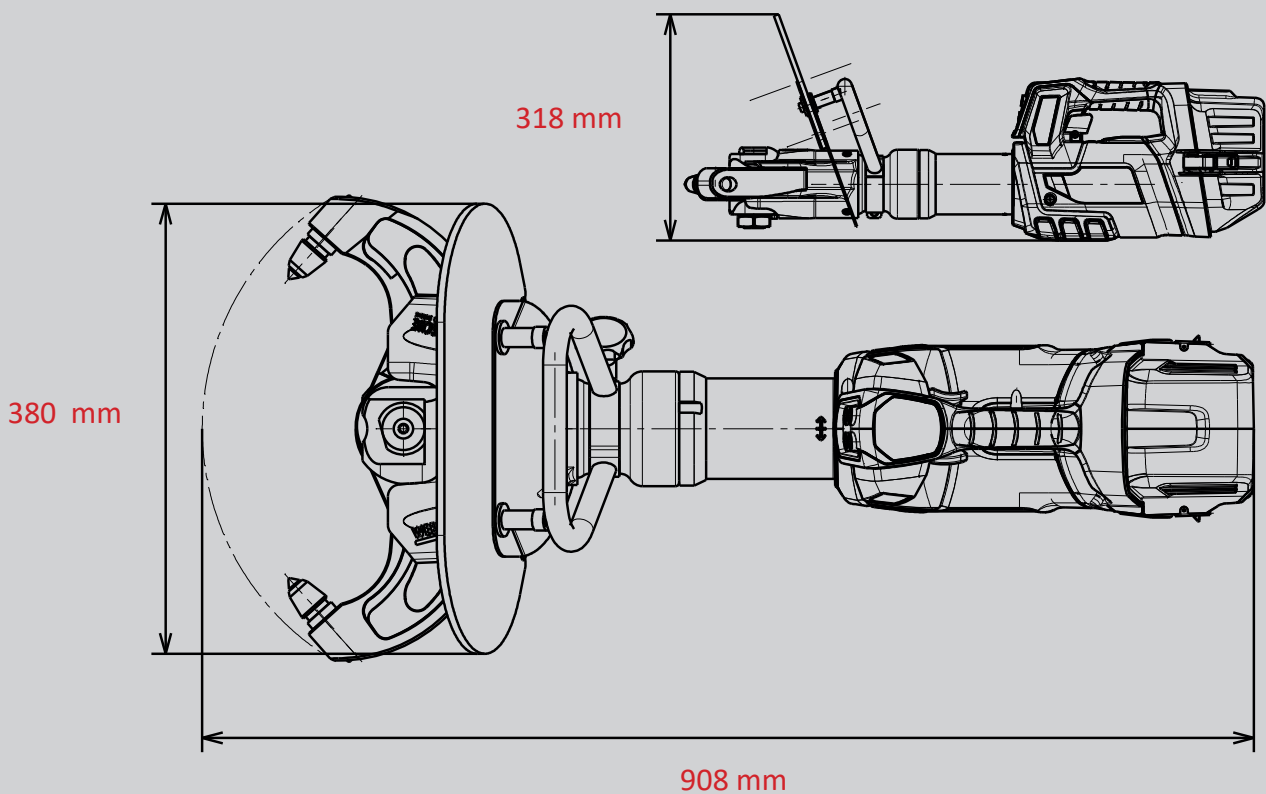

WEBER-HYDRAULIK GMBH

Heilbronner Straße 30
74363 Güglingen, Germany
Phone +49 7135 71-10270
info@weber-rescue.com

Emil Weber Platz 1
4460 Losenstein, Austria
Phone +43 7255 6237-120

Images are non-binding. We reserve the right to technical modifications.
05/2024A