

APPAREIL DE DÉCOUPE SPÉCIAL C 120 MK2 SMART-FORCE

Référence
1105135



**SMART
FORCE**
MORE THAN A RESCUE TOOL.

-  18V BATTERY
-  POW3R PUMP
-  CONNECT
-  FORGED
-  360° HANDLE
-  LED LIGHTS
-  UNDERWATER

Caractéristiques techniques :

Largeur d'ouverture	120 mm
Poids (opérationnel)	24,1 kg
Dimensions (LxlxH)	765 x 188 x 230 mm
Classification EN (DIN EN 13204)	AC120-D-24,1
Puissance de coupe EN (EN 13204)	1D-2D-3E-4F-5F
Classification NFPA (NFPA 1936)	A4-B3-C5-D6-E6-F3

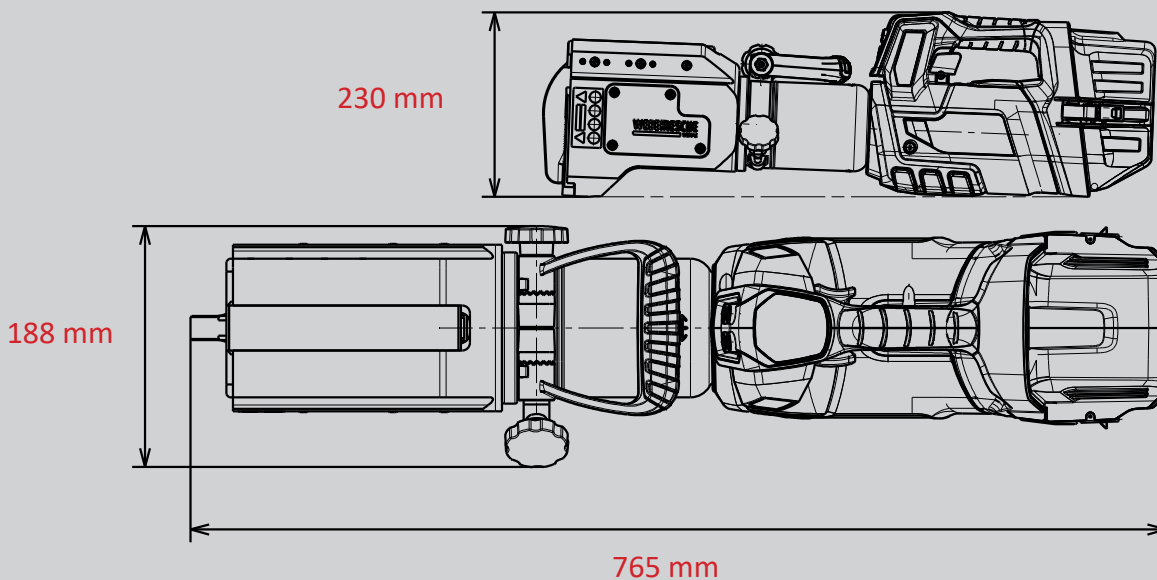

WEBER-HYDRAULIK GMBH

Heilbronner Straße 30
74363 Güglingen, Germany
Phone +49 7135 71-10270
info@weber-rescue.com

Emil Weber Platz 1
4460 Losenstein, Austria
Phone +43 7255 6237-120

Images non contractuelles. Toutes modifications techniques réservées.
05/2024A