

# CALE D'ÉCARTEMENT SPK 250 MK2 E-FORCE3

# E FORCE 3

Référence  
**1101981**



 CHARGE

 SPEED CONTROL

 LED LIGHTS

## Caractéristiques techniques:

Largeur d'écartement	61 mm
Force d'écartement (dans la zone de travail)	248 kN
Poids (opérationnel)	12,9 kg
Dimensions (LxlxH)	770 x 150 x 241 mm

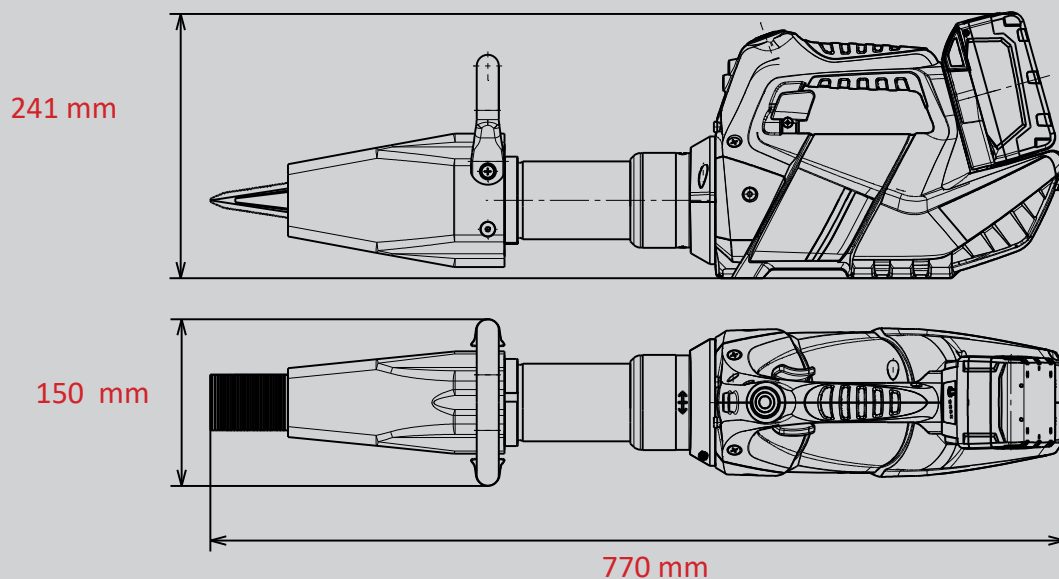

**WEBER-HYDRAULIK GMBH**  
Heilbronner Straße 30  
74363 Güglingen/Deutschland  
Fon +49 7135/71-10270  
Fax +49 7135/71-10396  
info@weber-rescue.com

Emil Weber Platz 1  
4460 Losenstein/Österreich  
Fon +43 7255/6237-120  
Fax +43 7255/6237-12461  
info@weber-rescue.com

Images non contractuelles. Toutes modifications techniques réservées.  
10/2023A