

SPREIZER SP 44 AS

Teile-Nr.
1093667



-  GRIP
-  360° HANDLE
-  LIGHTWEIGHT
-  PEELING
-  PUSH CONTROL
-  SINGLE
-  X-CHANGE

Technische Daten:

Spreizweite	610 mm
Spreizkraft (im Arbeitsbereich)	44 - 857 kN
Max. Quetschkraft	149,0 kN
Zugweite	465 mm
Max. Zugkraft	68,0 kN
Gewicht	13,4 kg
Ölbedarf	0,1 l
Abmessungen (LxBxH)	715 x 239 x 176 mm
Nenndruck	700 bar
EN-Klassifizierung (EN 13204)	AS44/610-13,4

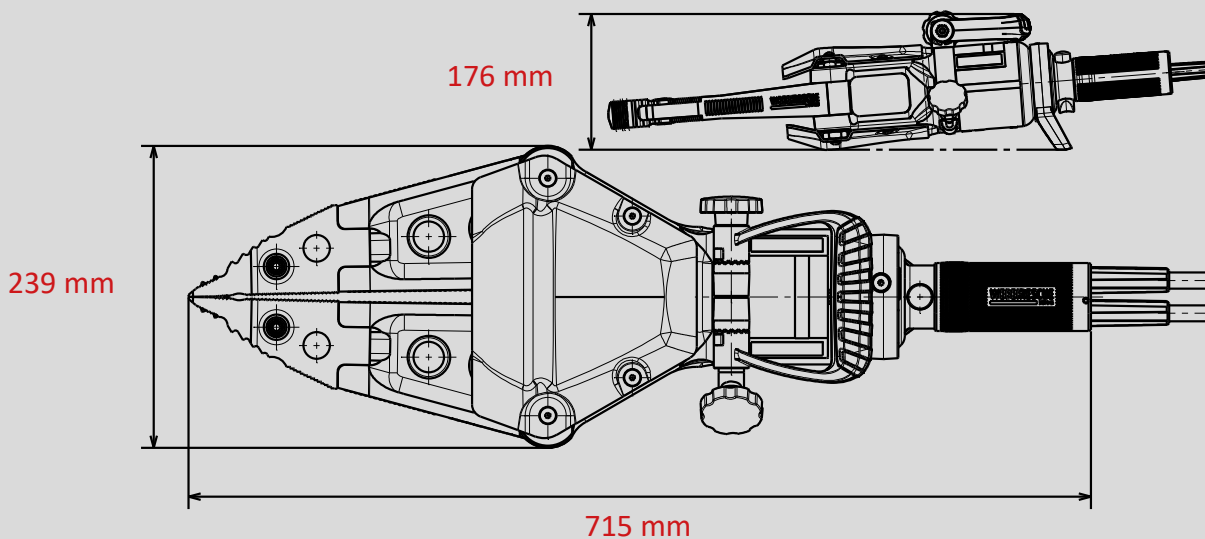

Abbildungen unverbindlich. Technische Änderungen vorbehalten.
60004868 (-, -, ALL, 25.06.2020)